

TX7140

Intelligent Manual Call Point Installation and Operation Manual



Product Safety

To prevent severe injury and loss of life or property, read the instruction carefully before installing the manual call point to ensure proper and safe operation of the system.



European Union directive

2012/19/EU (WEEE directive): Products marked with this symbol cannot be disposed of as unsorted municipal waste in the European Union. For proper recycling, return this product to your local supplier upon the purchase of equivalent new equipment, or dispose of it at designated collection points.

For more information please visit the website at www.recyclethis.info

Table of Content

1 Introduction 4

 1.1 Overview 4

 1.2 Feature and Benefits 4

 1.3 Technical Specification 4

2 Installation 5

 2.1 Installation Preparation 5

 2.2 Installation and Wiring 5

3 Manual Call Point Configuration 6

 3.1 Preparation 6

 3.2 Addressing 6

 3.3 Read Configuration 6

4 General Maintenance 7

 4.1 Resetting Manual Call Point 7

5 Troubleshooting Guide 8

Appendix 1 8

 Limitation of Manual Call Point 8

1 Introduction

1.1 Overview

The TX7140 Intelligent Manual Call point use a non-breakable glass which is designed to press under light pressure triggering the call point into an alarm condition, with LED indicator mounted onto the front face to simplify the location of an operated call point. Safe to press and no hammer is required. The protected flap on the lower part is used for reset through supplied special tool.

In the event of fire, once it is pressed, the LED goes on indicate the call point status and parallel sending communication signal to the control panel. The TX7140 manual call point is compatible to the TX7004 Analogue Intelligent Fire Alarm Control Panel, produced by single manufacture T&A, to avoid addressable communication compatibility problem.

1.2 Feature and Benefits

- EN54-11 Compliance
- Using microprocessor technology
- Digital addressing
- Non-breakable glass and hammerless
- Safe to operate and easy to reset
- Surface mounted, indoor application

1.3 Technical Specification

• Listed	LPCB Pending
• Compliance	EN54-11
• Input Voltage	24VDC [16V to 28V]
• Current Consumption Standby	0.6mA, Alarm: 1.1mA
• Protocol/Addressing	T&A, Value range from 1 to 254
• Indicator	Single LED / Steady On-when pressed
• Material / Colour	ABS / RED Glossy finishing
• Dimension	95 mm x 95 mm x 46 mm
• Weight	148g (with Base), 95g (without Base)
• Class	Type A, Indoors
• Operating Temperature	-10°C to +55°C
• Ingress Protection Rating	IP43
• Humidity	0 to 95% Relative Humidity, Non condensing

2 Installation

2.1 Installation Preparation

This manual call point must be installed, commissioned and maintained by a qualified or factory trained service personnel. The installation must be installed in compliance with all local codes having a jurisdiction in your area or BS 5839 Part 1 and EN54.

2.2 Installation and Wiring

1. Mount the call point standard base on standard one gang electrical back box. Follow the arrow mark for the correct position. Do not over-tighten the screws otherwise the base will twist. Use two M4 standard screws.
2. Connect the wire in terminal as shown in Figure two [2]. Verify the device number using handheld programmer then stick on the label before attaching call point. The sticker labels are available on the control panel.
3. Align the call point and tabs and gently pushing the call point until it locks into place.

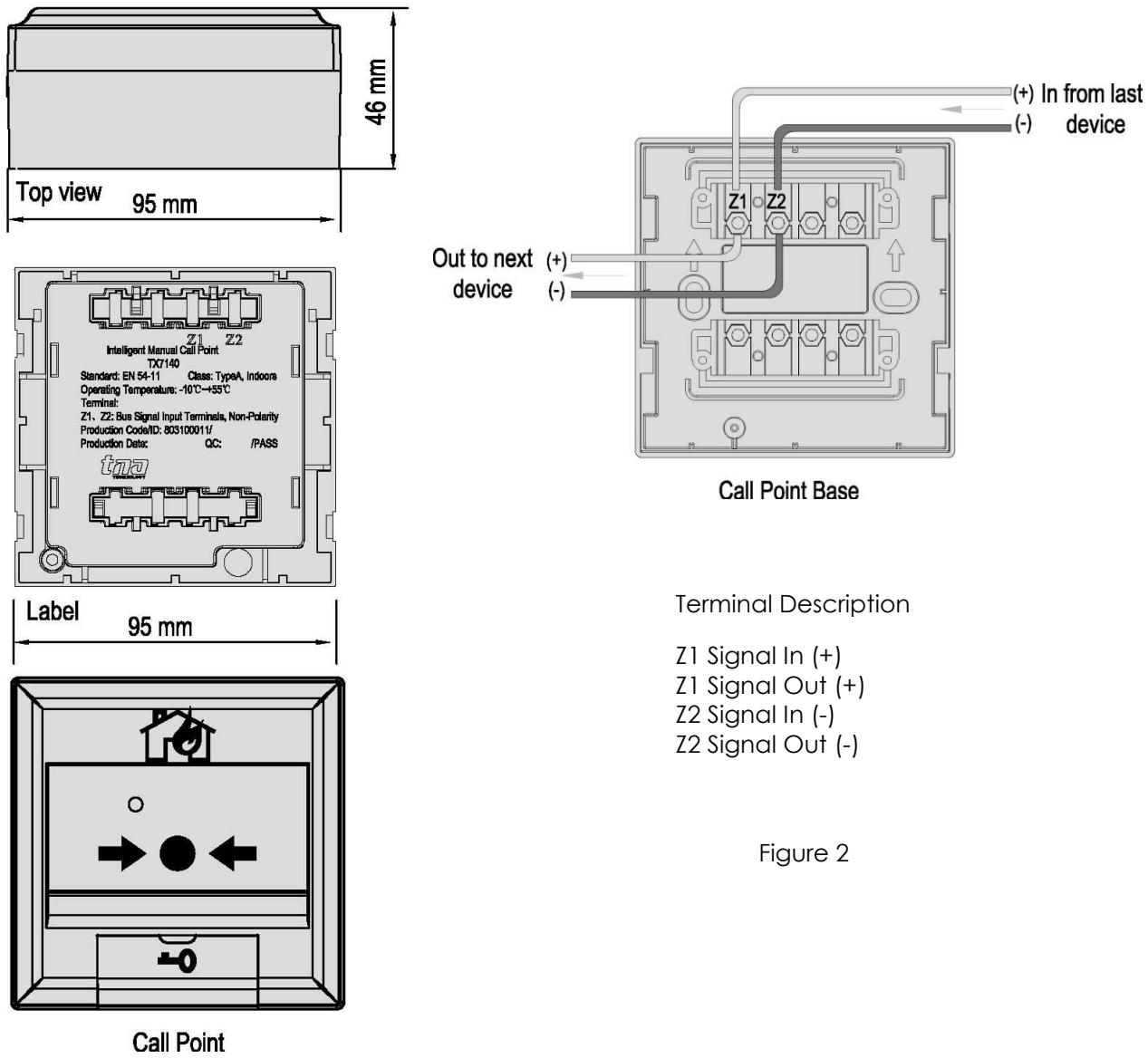

Figure 1

Figure 2

3 Manual Call Point Configuration

3.1 Preparation

The TX7930 handheld programmer is used to configure manual call point soft address. This tool is not included, must be purchased separately. The programmer is packed with twin 1.5V AA battery and cable, ready for usage once received.

Program a unique address number for each device according to the project layout before placing from the Terminal Base.

Warning: Disconnect the loop connection whilst connecting to the handheld programmer.

3.2 Addressing

1. Connect the programming cable to Z1 and Z2 terminals (Figure 3). Press **"Power"** to switch on the unit.
2. Switch-on the programmer, then press button **"Write"** or number **"2"** to enter Write Address mode (Figure 4).
3. Input the desire device address value from 1 to 254, and then press **"Write"** to save the new address (Figure 5).

Note: If display **"Success"**, means the entered address is confirmed. If display **"Fail"**, means failure to program the address (Figure 6).

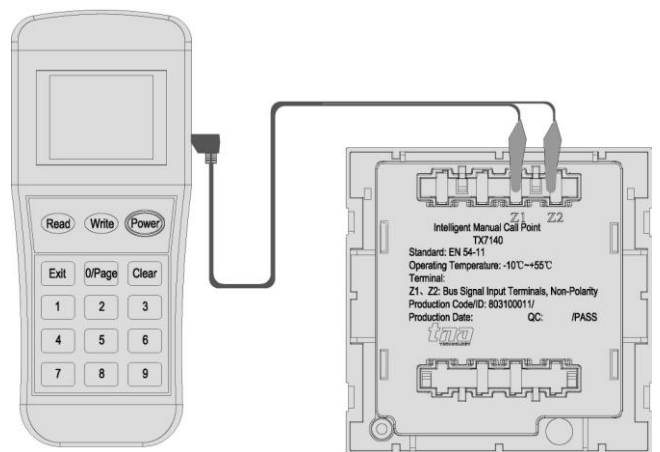

Figure 3

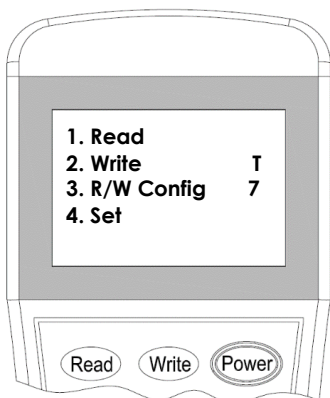

Figure 4

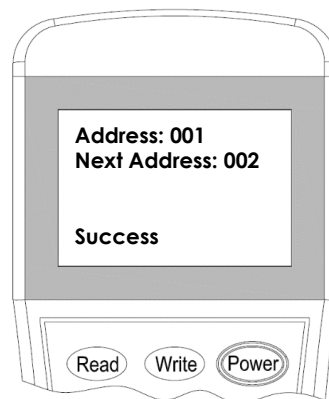

Figure 5



Figure 6

4. Press **"Exit"** key to go back Main Menu. Press **"Power"** key to switch-off the programmer.

3.3 Read Configuration

1. Attach the programming cable to Z1 and Z2 terminals of manual call point. Press **"Power"** to switch on the unit.
2. Switch-on the programmer, then press button **"Read"** or **"1"** to enter to Read mode (Figure 7). The programmer will display the configuration after few seconds (Figure 8).
3. Press **"Exit"** key to go back Main Menu. Press **"Power"** key to switch off the programmer.

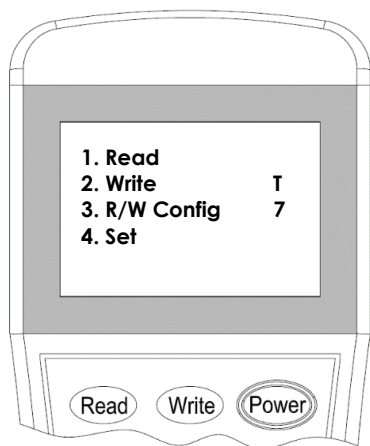

Figure 7

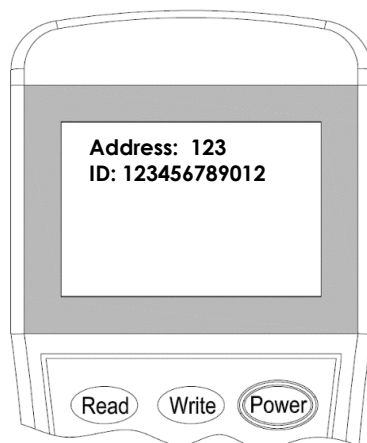

Figure 8

Read Description

Address: Unique number assigned
ID: Device serial number

4 General Maintenance

1. Inform the suitable personnel before conducting the maintenance.
2. Disable the manual call point on the control panel to prevent false alarm.
3. Do not attempt to adjust or modify the manual call point, it may affect the ability of the device to respond to a fire condition and will void the manufacturer's warranty.
4. Use a damp cloth to clean the call point.
5. Notify again proper personnel after conducting the maintenance and make sure to enable the manual call point and confirm if up and running.
6. Perform the maintenance on semi-annually or quarterly depending on the site conditions.

4.1 Resetting Manual Call Point

1. Ensure the fire is cleared before resetting the call point.
2. Open the protected flap and insert the supplied reset key into the key hole. (Figure 9).
3. Rotate the key clockwise position up to 90-degree angle (Figure 10), then forcibly push the key inside until the glass plate completely return to its normal position. (Figure 11)

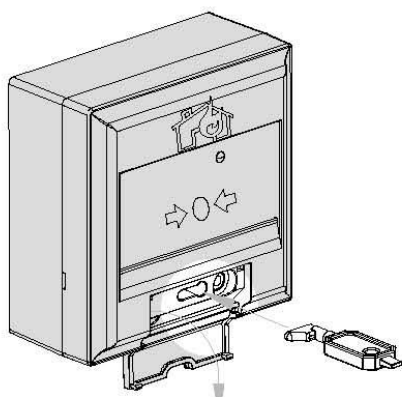

Figure 9

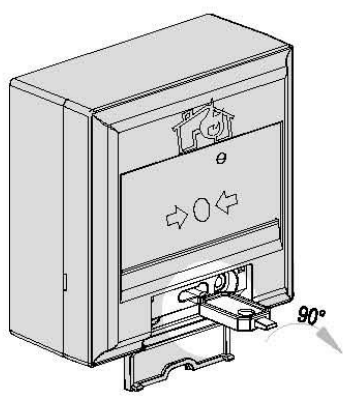

Figure 10

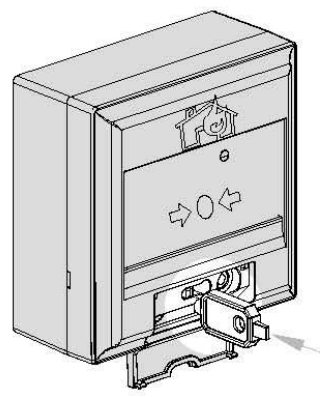

Figure 11

5 Troubleshooting Guide

What you notice	What it means	What to do
Address not enrolling	The wiring is loose The address is duplicate	Conduct maintenance Re-Commission the call point
Unable to commission	The damage the electronic circuit	Replace the call point unit
No alarm when pressed	The damage mechanical part	Replace the call point unit

Appendix 1

Limitation of Manual Call Point

The manual call point cannot last forever. In order to keep the call point working in good condition, please maintain the equipment continuously according to recommendations from manufacturers and relative nation codes and laws. Take specific maintenance measures on the basis of different environments.

This device contains electronic parts. Even though it is made to last for a long period of time, any of these parts could fail at any time. Therefore, test your manual call point weekly, different one once a week or least every half-year according to national codes or laws. Any manual call points, fire alarm devices or any other components of the system must be repaired and/or replaced immediately as they fail.